



Raytools AG

Email: [sales@raytools.com](mailto:sales@raytools.com)

Website: [www.raytools.ch](http://www.raytools.ch)

---









	$\leq$
	$\pm$

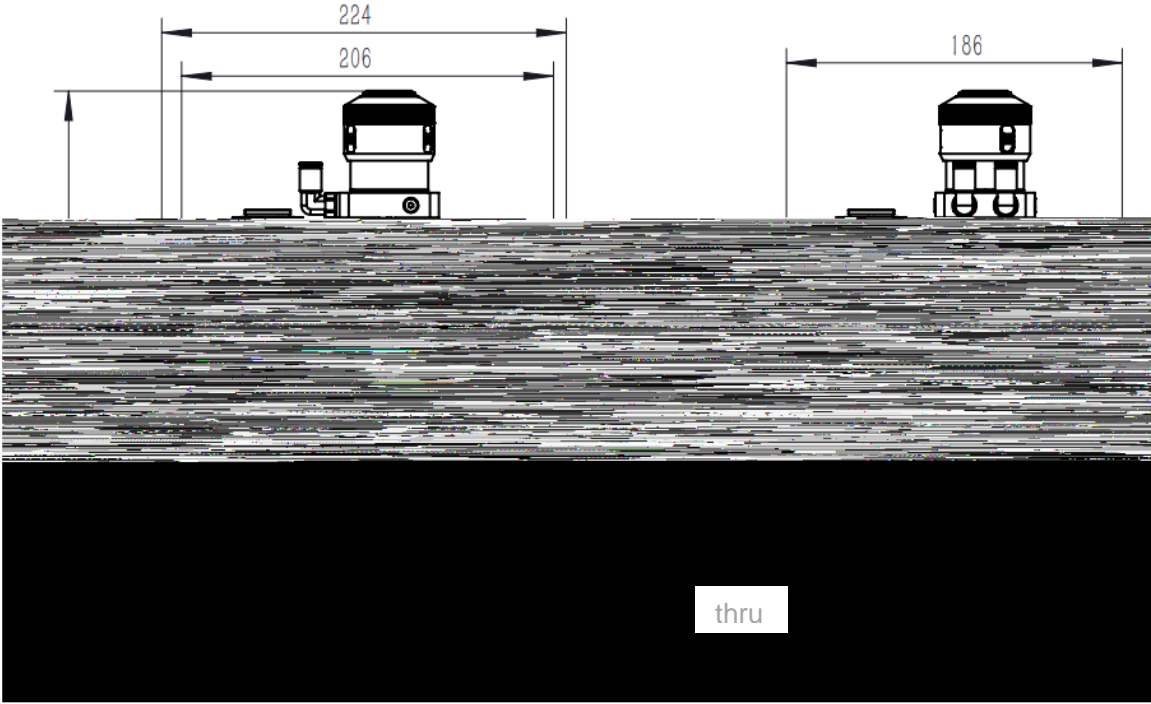

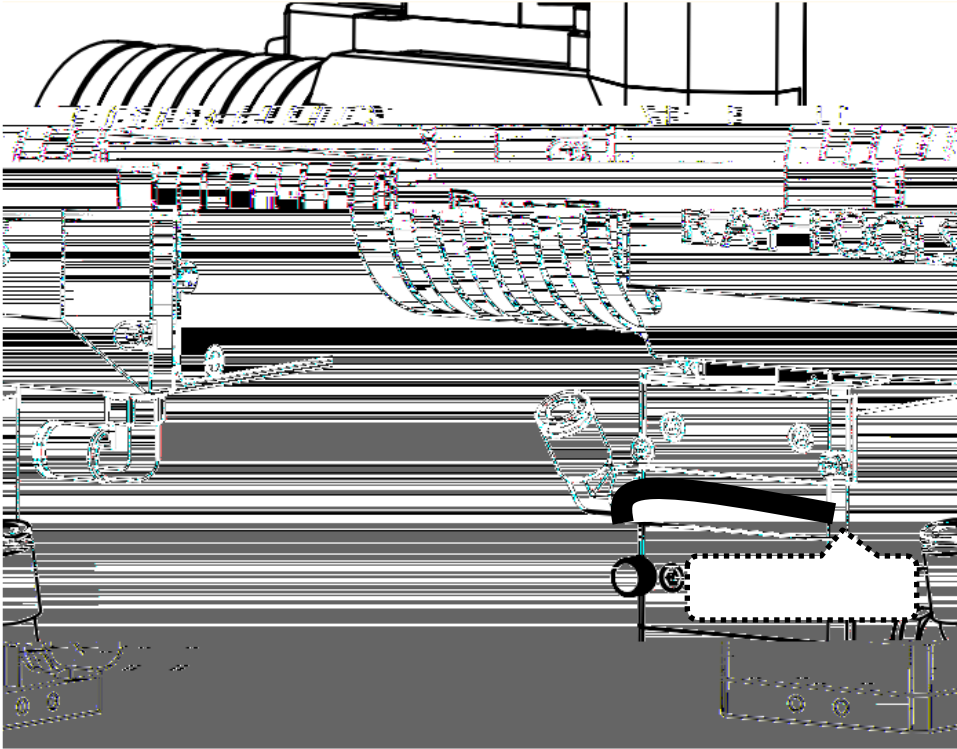



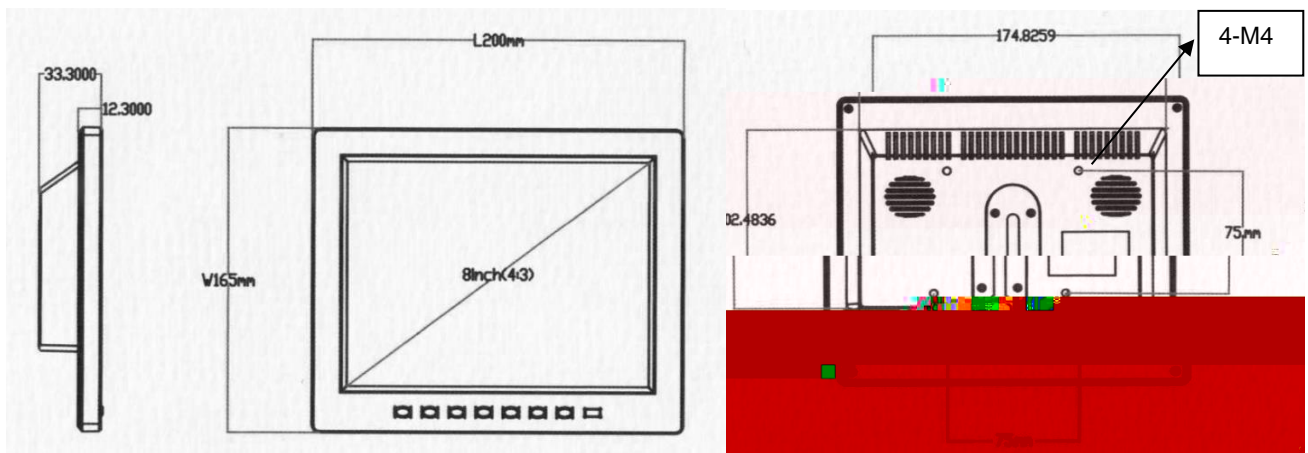
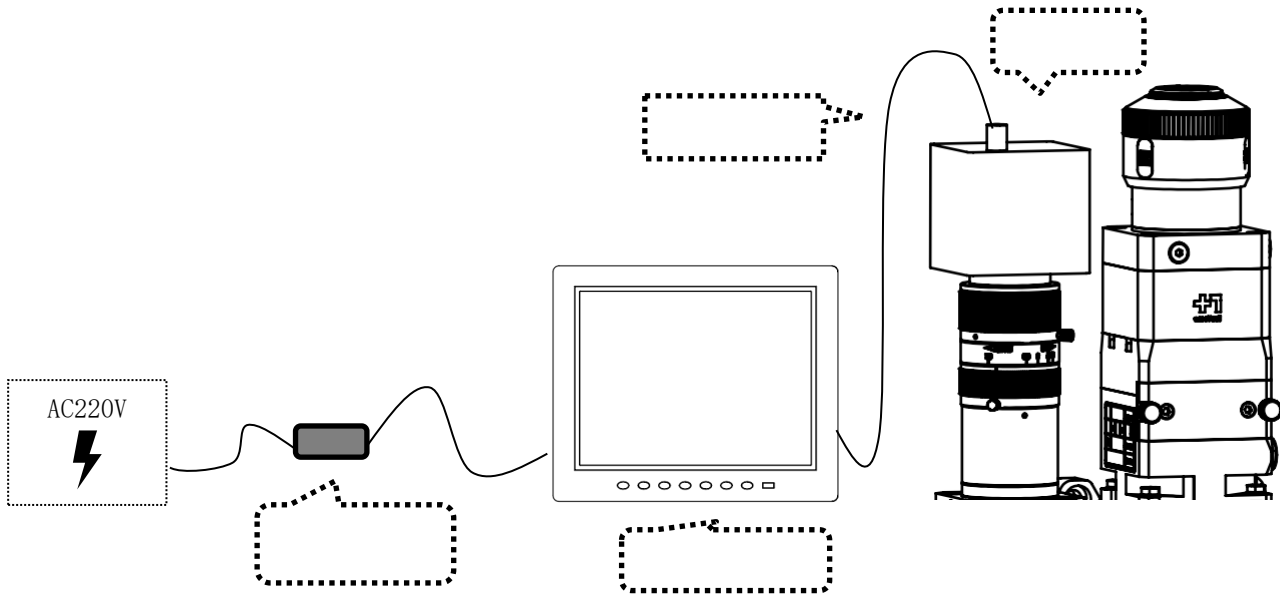

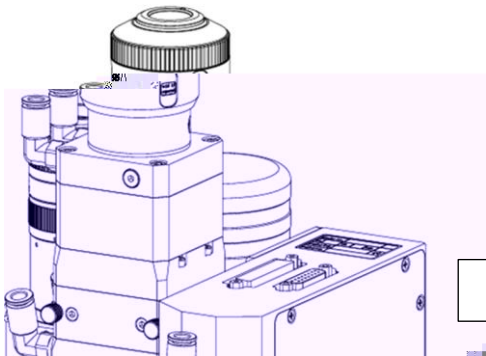

[Empty rectangular box]

			(65°C)
			< : >
			< : >

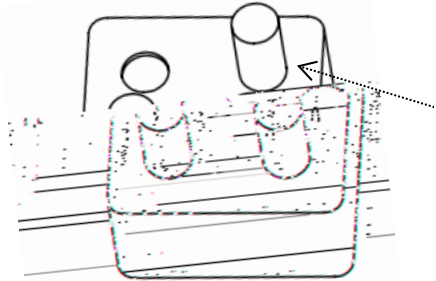
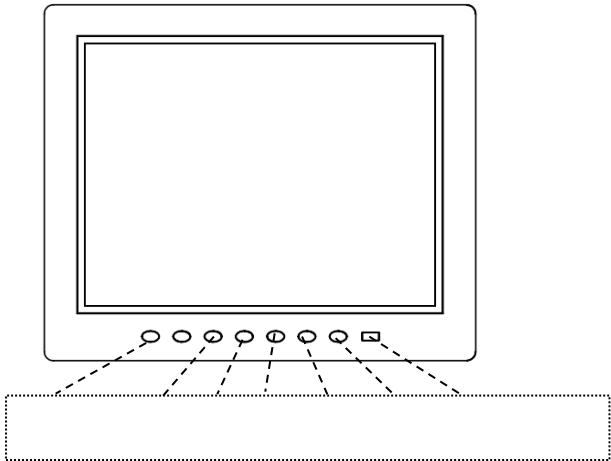
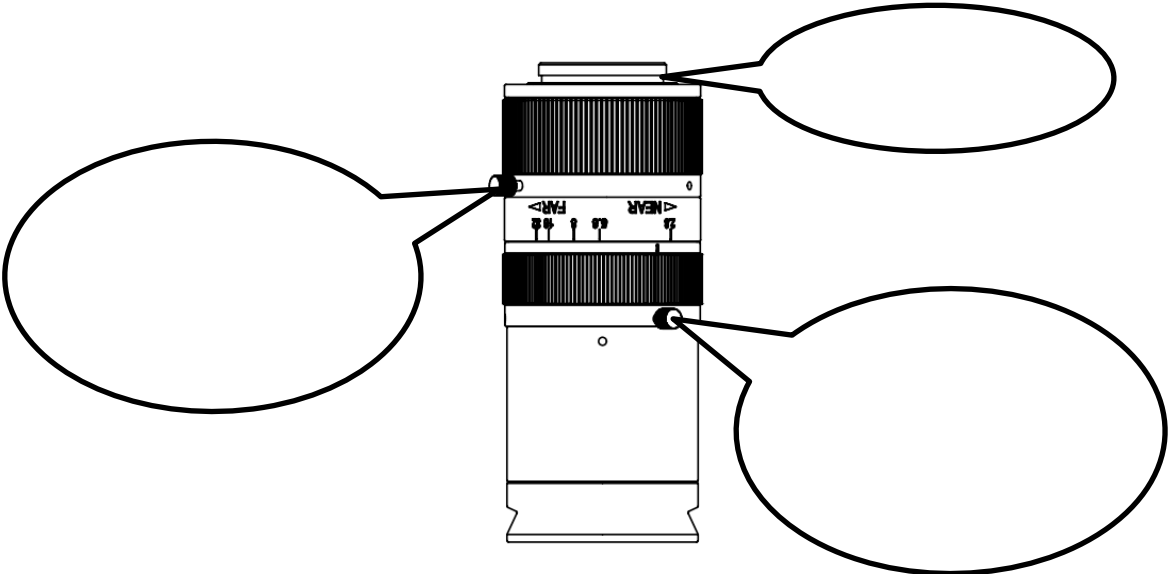

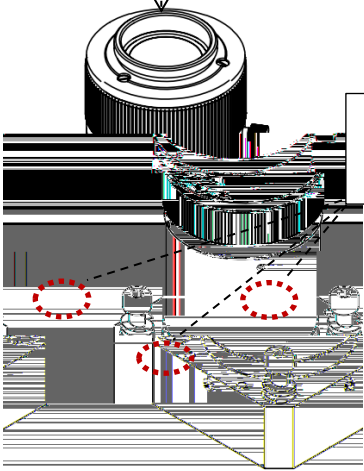
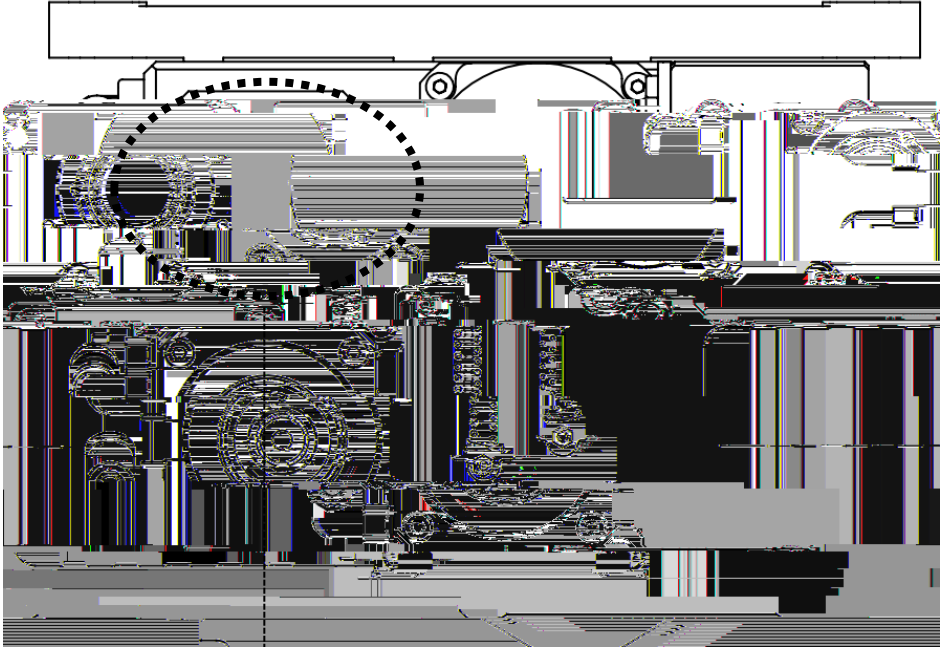

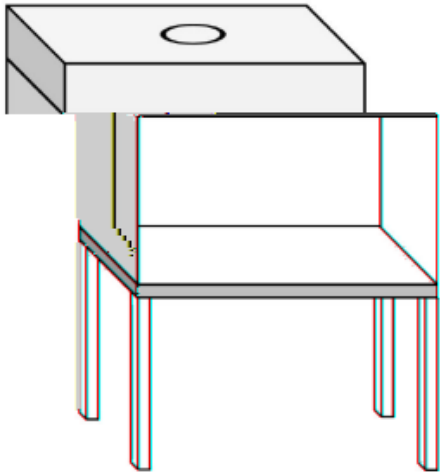

W



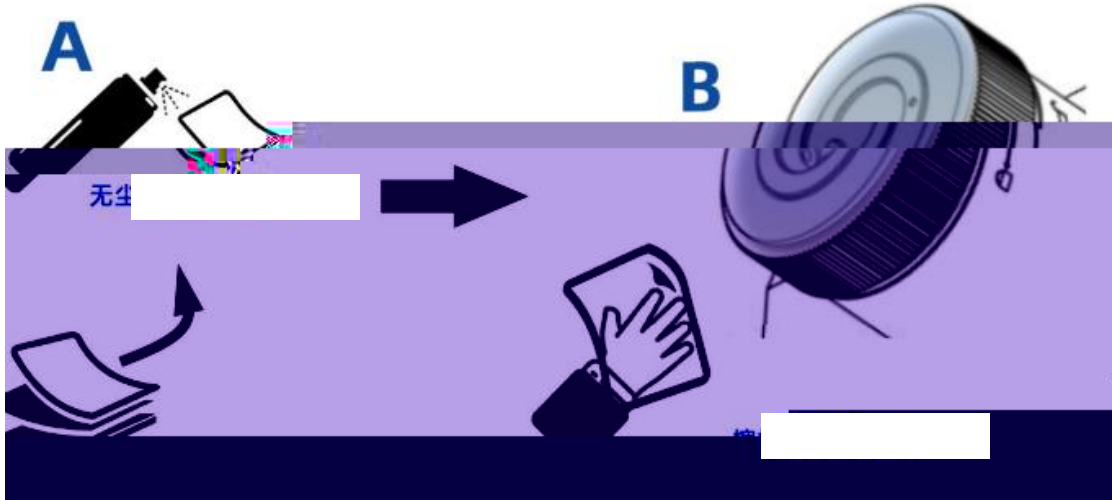

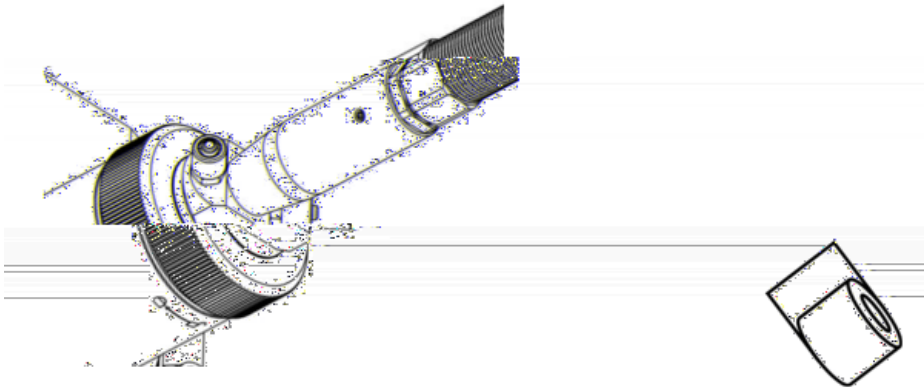
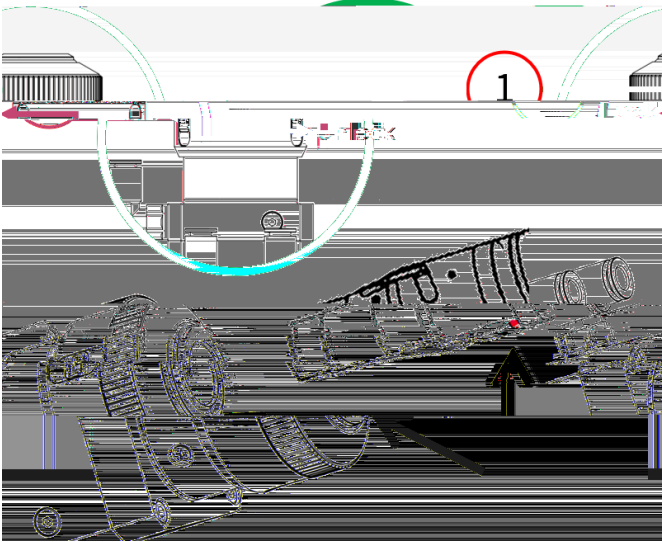

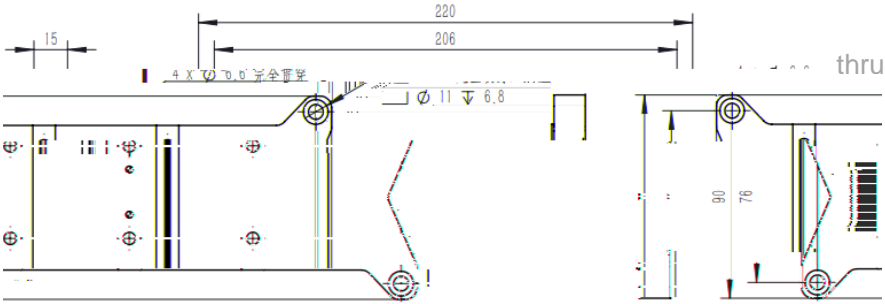
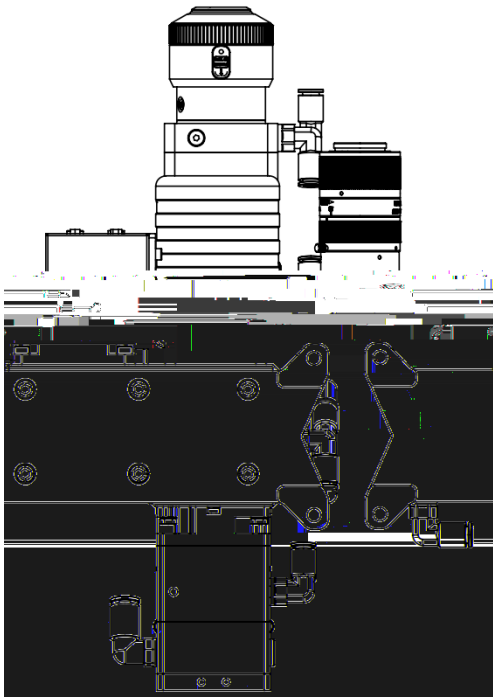

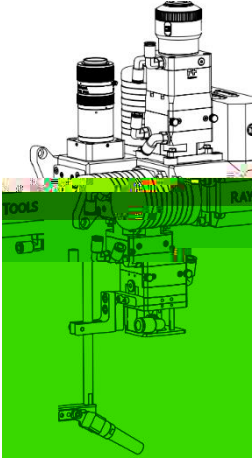
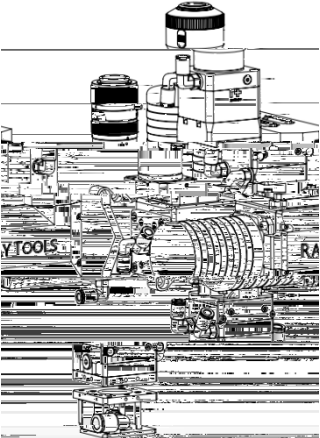
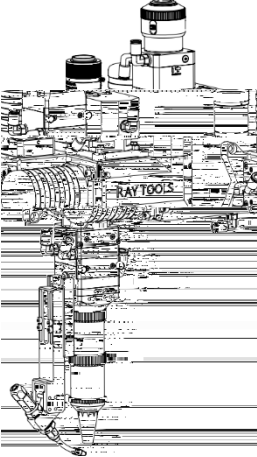
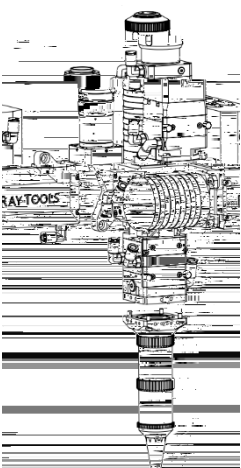
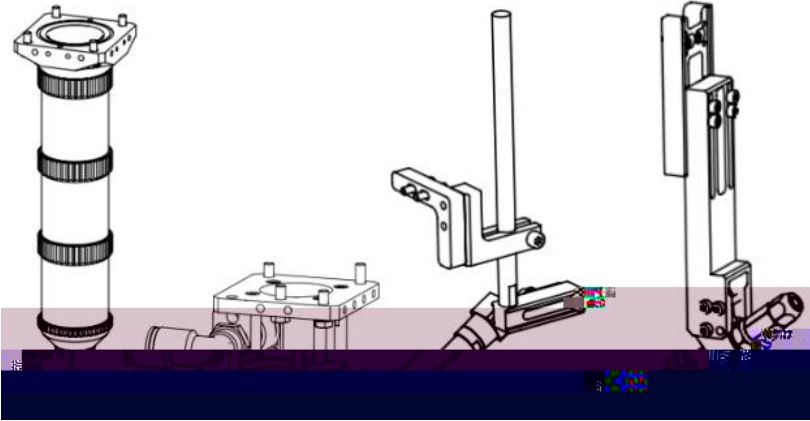

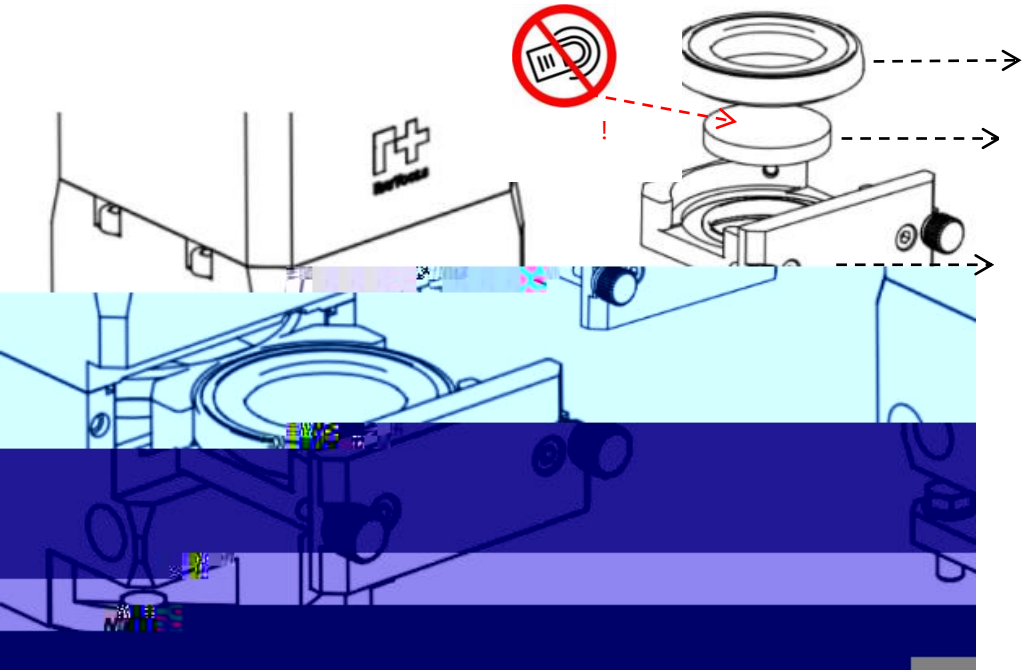

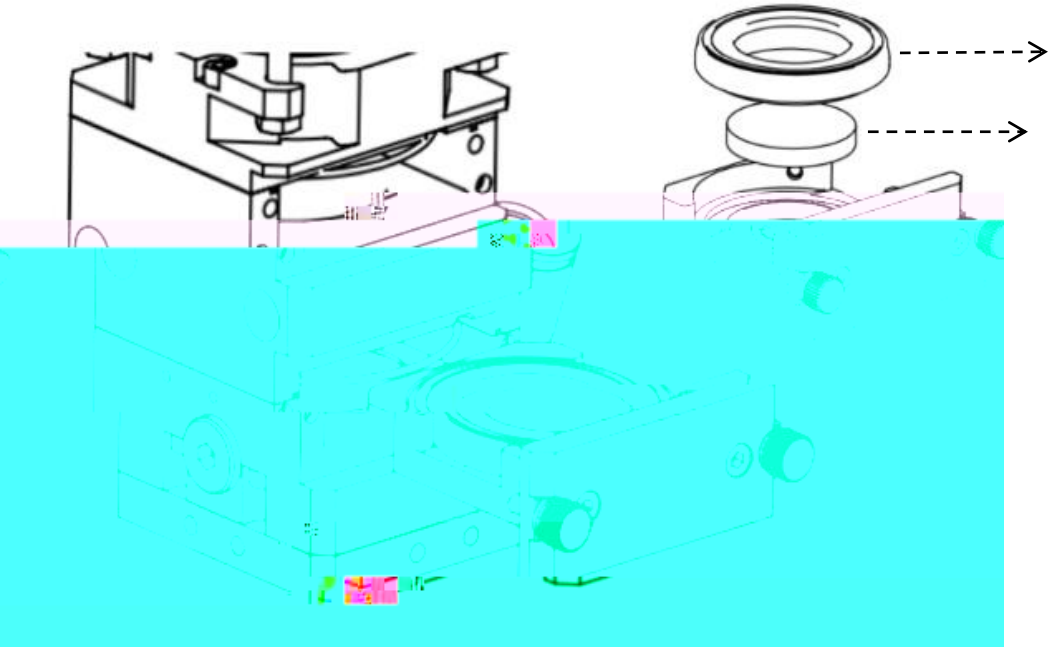

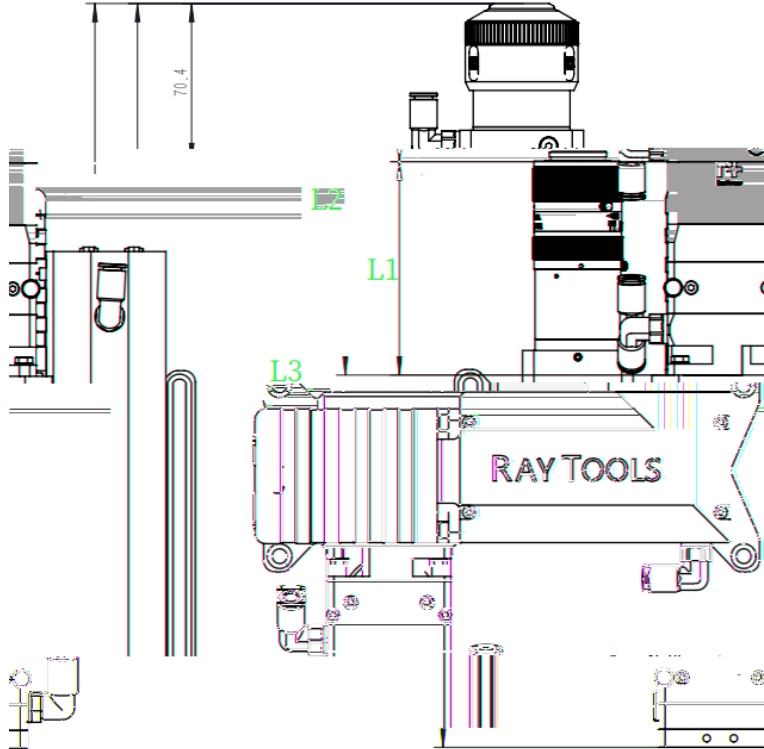



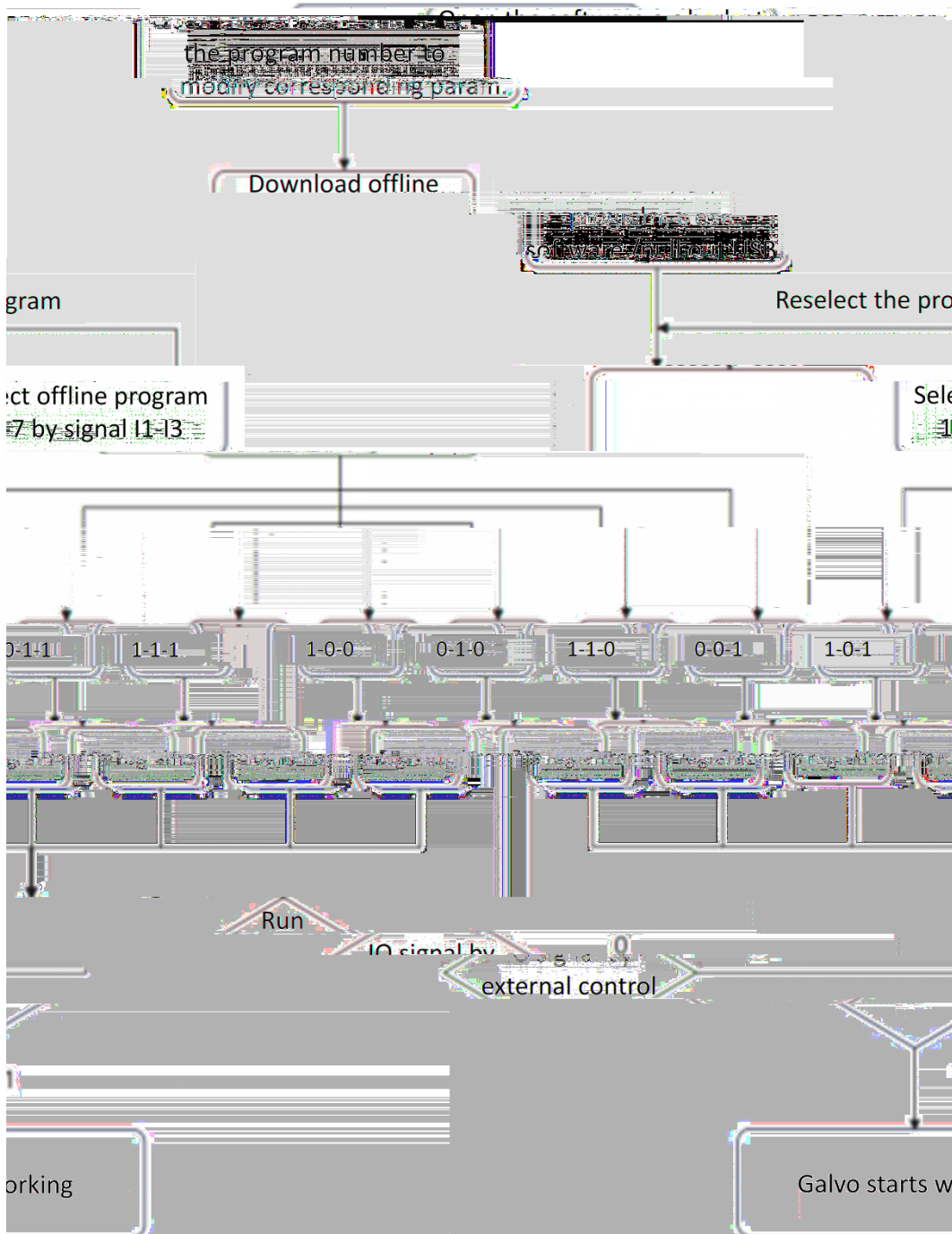

				/
				/



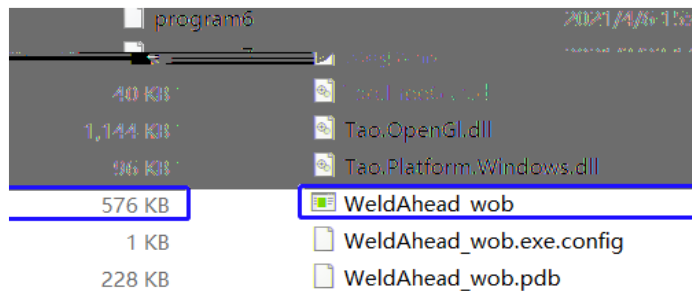
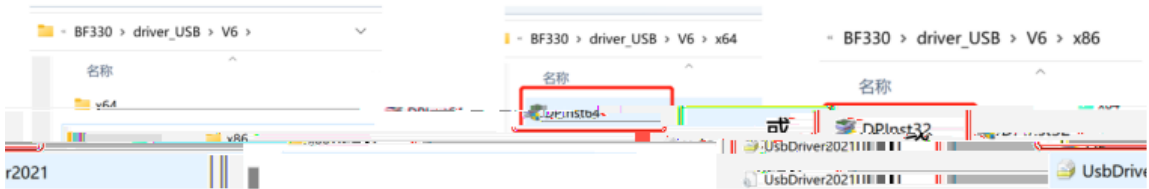



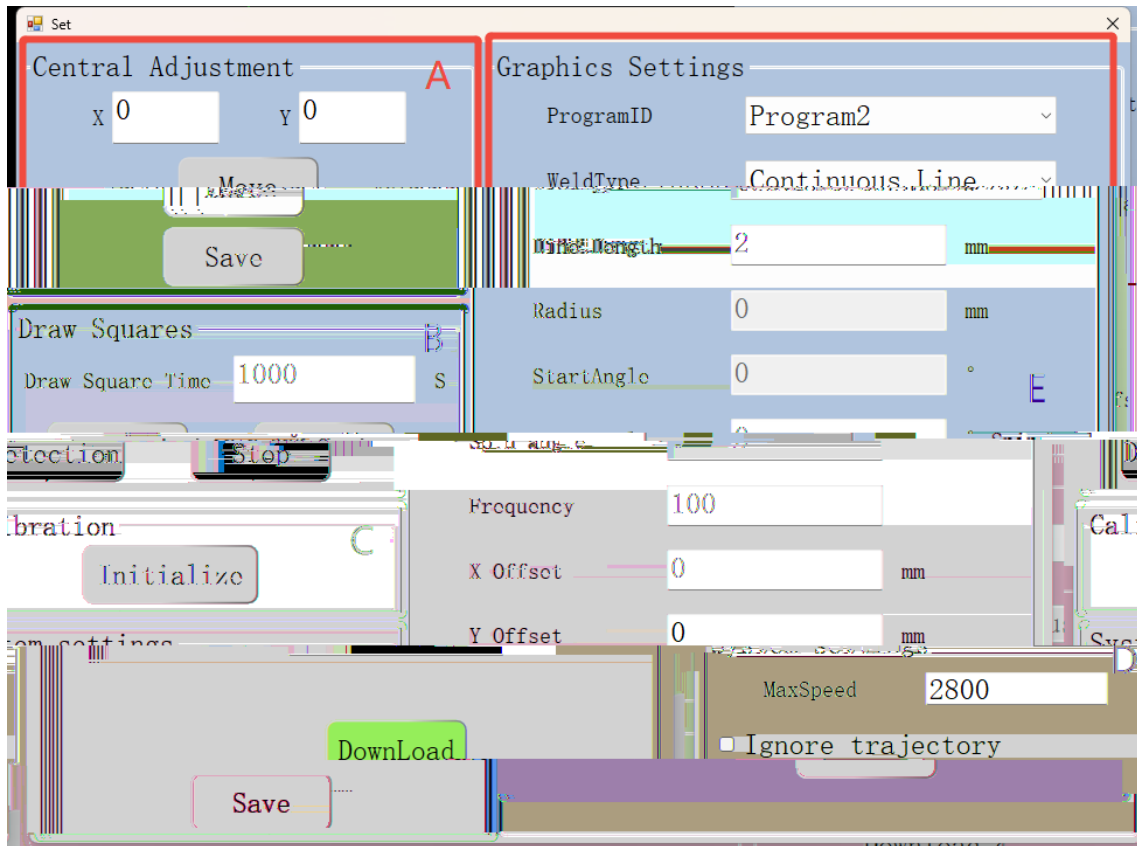



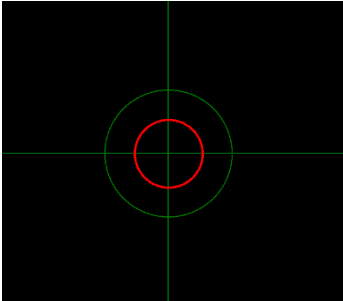

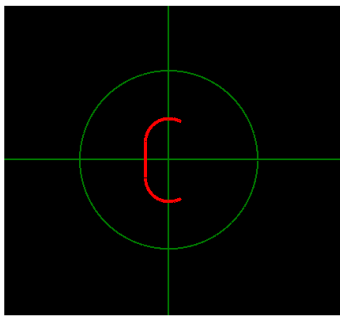

Graphics Settings

ProgramID	Program2
WeldType	Continuous C-type
Line Length	3 mm
Radius	2 mm
StartAngle	60 °
Spin angle	0 °
Frequency	66
X Offset	0 mm
Y Offset	0 mm

Download

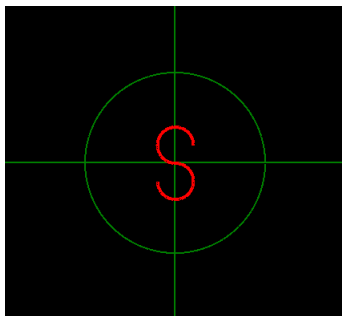

Graphics Settings

ProgramID	Program2
WeldType	Continuous S-type
Line Length	0 mm
Radius	2 mm
StartAngle	60 °
Spin angle	0 °
Frequency	66
X Offset	0 mm
Y Offset	0 mm

Download

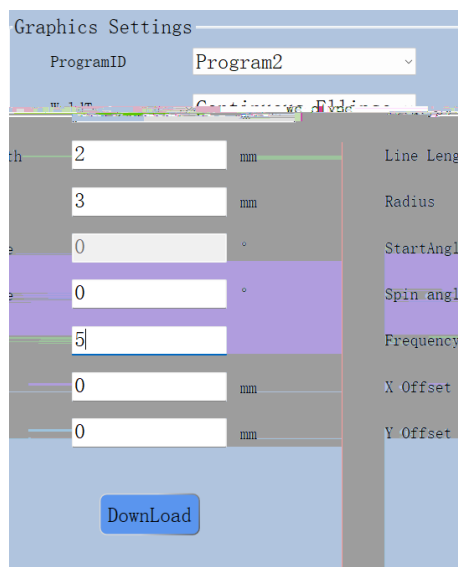
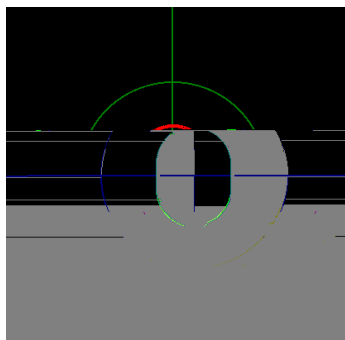
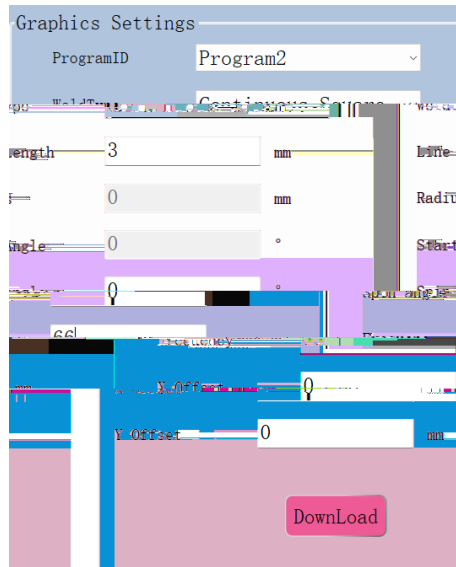
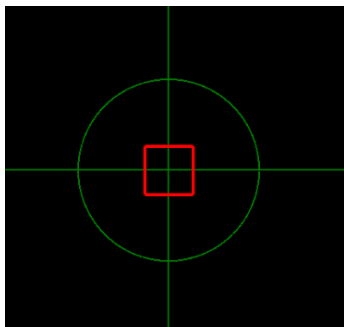

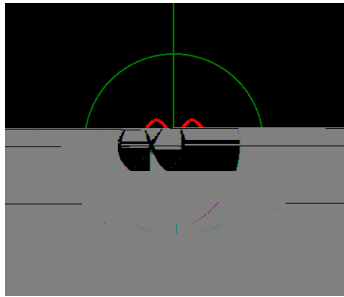

Graphics Settings

ProgramID	<input type="text" value="Program2"/>
WeldType	<input type="text" value="Continuous 8-type"/>
Line Length	<input type="text" value="0"/> mm
Radius	<input type="text" value="3"/> mm
StartAngle	<input type="text" value="0"/> °
Spin angle	<input type="text" value="0"/> °
Frequency	<input type="text" value="40"/>
X Offset	<input type="text" value="0"/> mm
Y Offset	<input type="text" value="0"/> mm

[Download](#)

- 1.
- 2.
- 3.
  
- 4.
- 5.